



Made in the USA

Y2K
Year 2000
Compliant

305-RTD

Miniature Panel Thermometer

11434ML-02A



This device is marked with the international caution symbol. It is important to read the Setup Guide before installing or commissioning this device as it contains important information relating to safety and EMC.

It is the policy of NEWPORT to comply with all worldwide safety and EMC/EMI regulations that apply. NEWPORT is constantly pursuing certification of its products to the European New Approach Directives. NEWPORT will add the CE mark to every appropriate device upon certification.

© Copyright 1998, NEWPORT Electronics, Inc. All rights reserved.

This documentation may not be copied, photocopied, reproduced, translated, or reduced to any electronic medium or machine-readable form, in whole or in part, without prior written consent of NEWPORT Electronics, Inc.

TABLE OF CONTENTS

SECTION		PAGE
	Preface	ii
	Models Available	iii
Section 1	Introduction	1
1.1	Unpacking	1
1.2	Safety Considerations	2
Section 2	About the Meter	3
2.1	Front of the Meter	3
2.2	Back of the Meter	4
2.3	Connector Description	4
Section 3	Getting Started	5
3.1	Main Board Power Jumpers	5
3.2	Changing the Meter Parameters	7
3.3	Installation and Panel Mounting	10
3.4	Sensor Input Connections	12
3.5	Analog Output Connections	14
3.6	Display Hold Connections	15
3.7	Main Power Connections	16
3.8	Disassembly/Assembly	18
Section 4	Operation and Calibration	20
4.1	Equipment Required	20
4.2	Calibration Procedure	21
Section 5	Specifications	23
Section 6	Glossary	26

PREFACE

Manual Objectives: This manual shows you how to set up and use the RTD Panel Thermometer.

This meter is an economical Miniature Temperature Panel Thermometer featuring a large display with a linearized analog output that is supplied as a standard feature.

Each of the models* can be converted by the user to display in degrees Fahrenheit or Celsius between one degree and a tenth degree resolution.

RTD is an abbreviation for resistive temperature detector. The meter is designed to measure 100 ohm platinum resistance with 0.00385 temperature coefficient, also known as the European curve. The RTD will change resistance with a change in temperature. When using a 2-wire measurement configuration, lead wire impedance can contribute significant error to the temperature measurement. When using long lead wires a 3- or 4-wire measurement configuration is recommended.

The meter is available in platinum RTD with 2-, 3-, or 4-wire connections. All of the models listed in **Table 1-1** come standard with red LEDs, and can be ordered with a green LED display as an option. The part numbers would then end with "-GR".

Also, these meters can be ordered with different power configurations. Refer to **Table 1-3** for available choices.

*Refer to **Table 1-1** for the complete listing of models available.

MODELS AVAILABLE

TABLE 1-1

RTD MODELS AVAILABLE

The following 3-1/2 digit mini RTD panel meters are available and discussed in this Operator's Manual.

MODEL	TYPE	°C or °F	RESOLUTION
305-MF1	RTD	F	1.0°F
305-MF2	RTD	F	0.1°F
305-MC1	RTD	C	1.0°C
305-MC2	RTD	C	0.1°C

The accuracies and ranges are listed in Section 5.

Note 

TABLE 1-2

Power Options Available

MODEL	POWER
305-Mxx-C0	115 Vac \pm 15%, 50/60 Hz
305-Mxx-C1	230 Vac \pm 15%, 50/60 Hz
305-Mxx-C2A	9-26 Vdc @ 110mA max.
305-Mxx-C5	100 Vac \pm 15%, 50/60 Hz
305-Mxx-C8	24 Vac \pm 15%, 50/60 Hz

TABLE 1-3**Other Models Available**

The following 3-1/2 digit mini thermocouple panel thermometers are discussed in a separate manual.

MODEL	TYPE	°C or °F	RESOLUTION
305-JF1	J	F	1.0°F
305-JF2	J	F	0.1°F
305-JC1	J	C	1.0°C
305-JC2	J	C	0.1°C
305-KF1	K	F	1.0°F
305-KF2	K	F	0.1°F
305-KC1	K	C	1.0°C
305-KC2	K	C	0.1°C
305-TF1	T	F	1.0°F
305-TF2	T	F	0.1°F
305-TC1	T	C	1.0°C
305-TC2	T	C	0.1°C
305-EF1	E	F	1.0°F
305-EF2	E	F	0.1°F
305-EC1	E	C	1.0°C
305-EC2	E	C	0.1°C

NOTES, WARNINGS and CAUTIONS

Information that is especially important to note is identified by these labels:



NOTE: provides you with information that is important to successfully setup and use the Programmable Digital Meter.

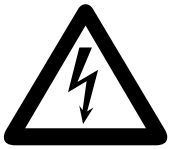

CAUTION or WARNING: tells you about the risk of electric shock.



CAUTION, WARNING or IMPORTANT: tells you of circumstances or practices that can effect the meter's functionality and must refer to accompanying documents.

SECTION 1 INTRODUCTION

1.1 UNPACKING

Remove the Packing List and verify that all equipment has been received. If there are any questions about the shipment, use the phone number for the Customer Service Department nearest you.

Upon receipt of shipment, inspect the container and equipment for any signs of damage. Take particular note of any evidence of rough handling in transit. Immediately report any damage to the shipping agent.



The carrier will not honor any claims unless all shipping material is saved for their examination. After examining and removing contents, save packing material and carton in the event reshipment is necessary.

Verify that you received the following items in the shipping box:

QTY DESCRIPTION

- 1 Panel Thermometer with 3 small connectors plugged into the rear of the meter.

- 1 Operator's Manual

1.2 SAFETY CONSIDERATIONS



This device is marked with the international caution symbol. It is important to read this manual before installing or commissioning this device as it contains important information relating to Safety and EMC (Electromagnetic Compatibility).

Unpacking & Inspection

Unpack the instrument and inspect for obvious shipping damage. Do not attempt to operate the unit if damage is found.

Note

This instrument is a panel mount device protected in accordance with Class I of EN 61010 (115/230 AC power connections). Installation of this instrument should be done by Qualified personnel. In order to ensure safe operation, the following instructions should be followed.

This instrument has no power-on switch. An external switch or circuit-breaker shall be included in the building installation as a disconnecting device. It shall be marked to indicate this function, and it shall be in close proximity to the equipment within easy reach of the operator. The switch or circuit-breaker shall not interrupt the Protective Conductor (Earth wire), and it shall meet the relevant requirements of IEC 947-1 and IEC 947-3 (International Electrotechnical Commission). The switch shall not be incorporated in the mains supply cord.

Furthermore, to provide protection against excessive energy being drawn from the mains supply in case of a fault in the equipment, an overcurrent protection device shall be installed.



- The **Protective Conductor** must be connected for safety reasons. Check that the power cable has the proper Earth wire, and it is properly connected. It is not safe to operate this unit without the Protective Conductor Terminal connected.

Note

- Do not exceed voltage rating on the label located on the top of the instrument housing.
- Always disconnect power before changing signal and power connections.
- Do not use this instrument on a work bench without its case for safety reasons.
- Do not operate this instrument in flammable or explosive atmospheres.
- Do not expose this instrument to rain or moisture.
- Unit mounting should allow for adequate ventilation to ensure instrument does not exceed operating temperature rating.
- Use electrical wires with adequate size to handle mechanical strain and power requirements. Install without exposing bare wire outside the connector to minimize electrical shock hazards.

EMC Considerations

- Whenever EMC is an issue, always use shielded cables.
- Never run signal and power wires in the same conduit.
- Use signal wire connections with twisted-pair cables.
- Install Ferrite Bead(s) on signal wires close to the instrument if EMC problems persist.

SECTION 2 ABOUT THE METER

2.1 Front of the Meter

Figure 2-1 shows the panel thermometer.



Figure 2-1. Panel Thermometer

Features:

Display: 3 1/2 Digit, 7-Segment Red or Green LED

Full-size: 14.2 mm (0.56") LED Display

Analog Output Standard

1/8 DIN Standard Panel Cutout

Removable Screw-Clamp Cable Connector

Display Hold Capability

2.2 Back of the Meter

Figure 2-2 illustrates the rear of the meter.

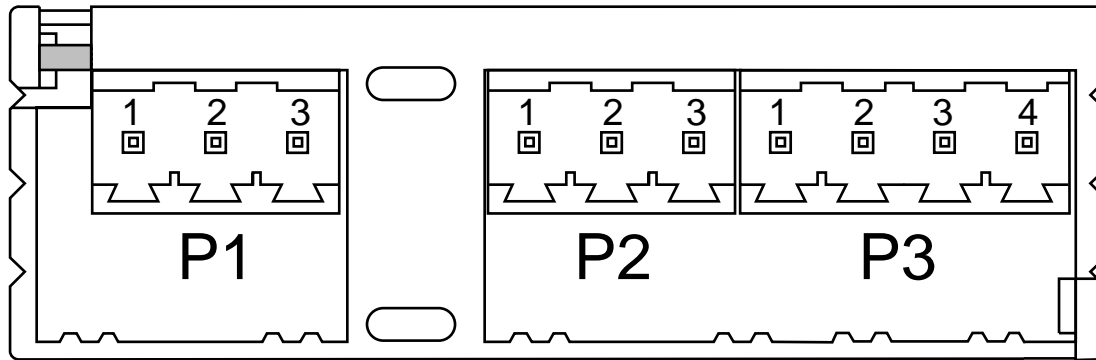

Figure 2-2. Rear View Showing P1, P2, P3 Locations

2.3 Connector Description

Connector Description	Connector	PIN #
(AC) Earth Ground	P1	1
(AC) Neutral	P1	2
(AC) Line	P1	3
(DC) -DC Return	P1	1
(DC) +DC	P1	2
(DC) No Connection (Not used)	P1	3
Display Hold (Active Low)	P2	1
Analog Return	P2	2
Analog Output	P2	3
RTD Input† -EXC	P3	1
RTD Input† Signal Lo	P3	2
RTD Input† Signal Hi	P3	3
RTD Input† +EXC	P3	4

† For RTD input wires, refer to **Figure 3-3** thru **3-6**.

SECTION 3 GETTING STARTED

3.1 Main Board Power Jumpers



Caution: The meter has no power-on switch, so it will be in operation as soon you apply power.

The meter can be configured to operate on 115VAC or 230VAC by the proper combination of the soldered wire jumpers that are located on the printed circuit board. The meter is set at the factory to be powered by the voltage specified at the time of ordering. The same transformer is used for either configuration, so all you need to do is to select the jumpers as described in this section.



Important: These changes must be performed by a qualified technician.

Note 

To change the Factory preset jumpers, do the following steps:

Disconnect the power from the unit before proceeding.

1. Remove the main board from the case. Refer to Disassembly/Assembly **Section 3.8**.
2. Locate the solder jumpers W1, W2, and W3 (located near the edge of the main board alongside the transformer).
3. If your power requirement is 115 V ac, solder jumpers W1 and W3 should be wired, but jumper W2 should not. If your power requirement is 230 Vac, solder jumper W2 should be wired, but jumpers W1 and W3 should not.

Voltage Jumper Pin Settings

AC VOLTAGE	INSTALL	REMOVE
115VAC	W1, W3	W2
230VAC	W2	W1, W3

Figure 3-1 shows the location of solder jumpers W1 through W3.

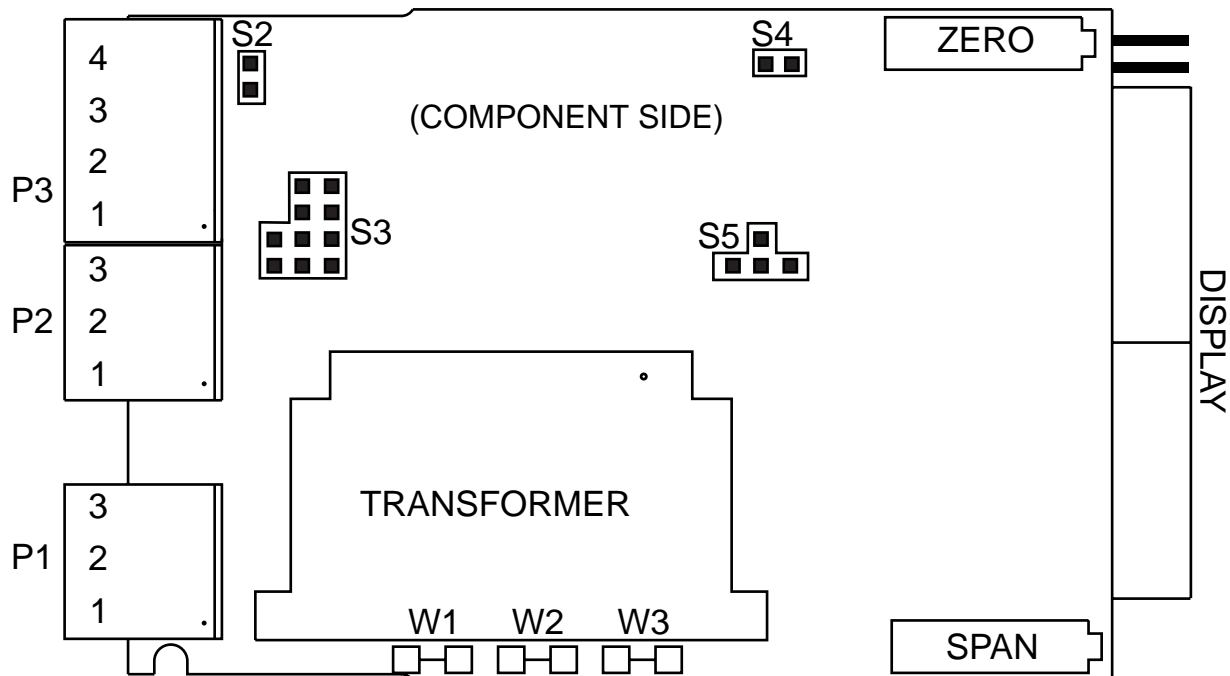

Figure 3-1. Power Jumper Locations

3.2 Changing the Meter Parameters

The proper combinations of jumper plugs S1, S2, S3, S4, and S5 inside the meter allow you to change various parameters of the meter. These parameters include resolution, range, units, RTD sensor configuration and sensor break configuration. You can change the parameters by moving the plugs on one or several of the jumper locations. Keep in mind that the meter is factory set for 3-wire RTD, and for the upscale position.

Figure 3-2 shows the location of the jumper plugs S1 through S5.

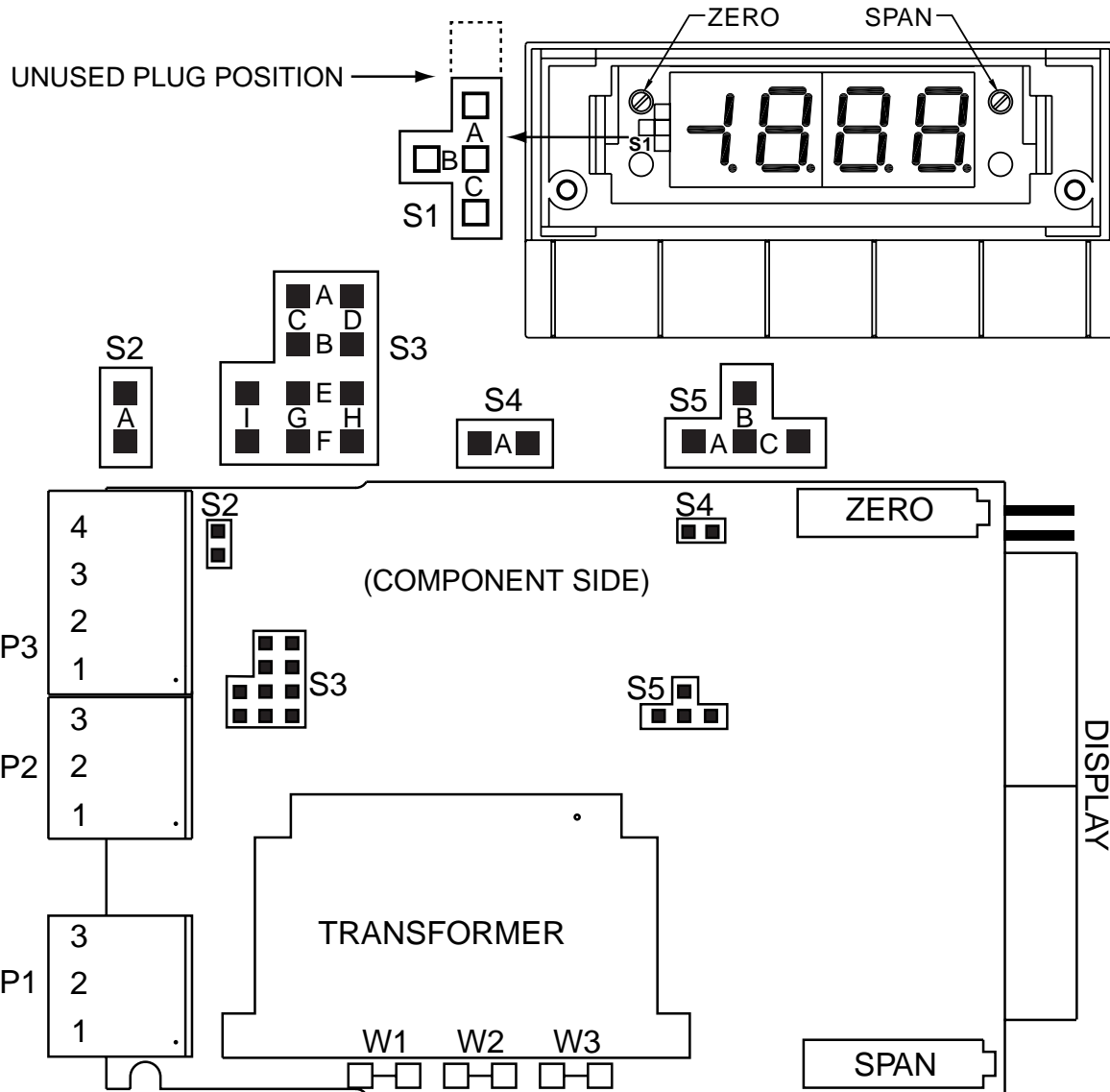

Figure 3-2. Jumper Plugs S1 through S5

The following tables summarize what parameters you can change.

TABLE 3-1 Range Parameters

Option	F/C	Resolution	Range	S1	S4	S5
*-MF1	°F	1°	-328 to + 1562°F	–	A	A
*-MF2	°F	0.1°	-199.9 to + 199.9°F	C	–	C
*-MC1	°C	1°	-200 to + 850°C	–	A	B
*-MC2	°C	0.1°	-199.9 to + 199.9°C	C	–	B

* Refer to **Table 1-1**, for complete models (preface section).

TABLE 3-2 2-, 3-, 4-Wire, Upscale, Downscale Configuration

Configuration	S2	S3	S3	
			Upscale (Default)	Downscale
2- or 4-wire RTD	--	--	A, B, E, F	C, D, G, H
3-Wire RTD	A	I	A, B, E, F	C, D, G, H

Note 

3-Wire input connection is standard. For 2- or 4-Wire remove S2-A and S3-I

Figure 3-3 gives an example of how to set S4 and S5 to configure a MF1 meter option. There is a jumper plug across A on S4 and another jumper plug across A on S5. B and C on S5 are not used.

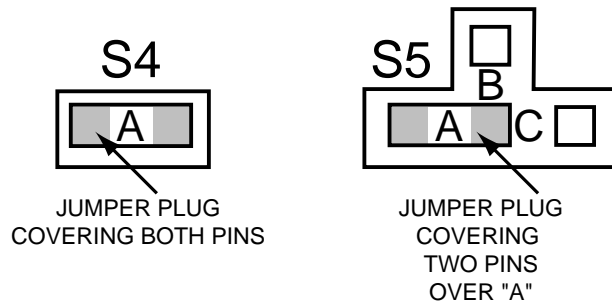

Figure 3-3. Example of How to Set Meter Option MF1 (jumpers S4 and S5)

SENSOR BREAK PROTECTION:

The proper combination of jumpers on S3 will determine the direction in which the display and analog output will go if the RTD sensor breaks (upscale or downscale). The meter is factory set to upscale break protection. If the sensor breaks, the display and analog signal will increment (upscale) and the 3 least significant digits will then go blank. If you require downscale break protection, refer to **Table 3-2** to change the S3 jumper configuration.

Section 3.3 Installation and Panel Mounting

Figure 3-4 shows the panel cutout dimensions, the dimensions for the panel thickness, and the backplate for mounting the unit in a panel. **Connections will be done after mounting the unit.**

1. Remove the 2 phillips screws from behind the display (you don't have to go inside the meter) holding the rectangular backplate to the meter. Remove the backplate and set aside.
2. Cut or punch a hole in the panel where you want the meter to go. The panel can be as thick as 0.25" (6.4mm) to as thin as 0.03" (0.8mm).
3. Insert the meter into the panel cutout.
4. From the rear of the panel, slide the backplate over the case (smooth side out).
5. Install the 2 phillips screws to secure the meter in 1/8 DIN mount. Center the meter in hole prior to tightening screws.

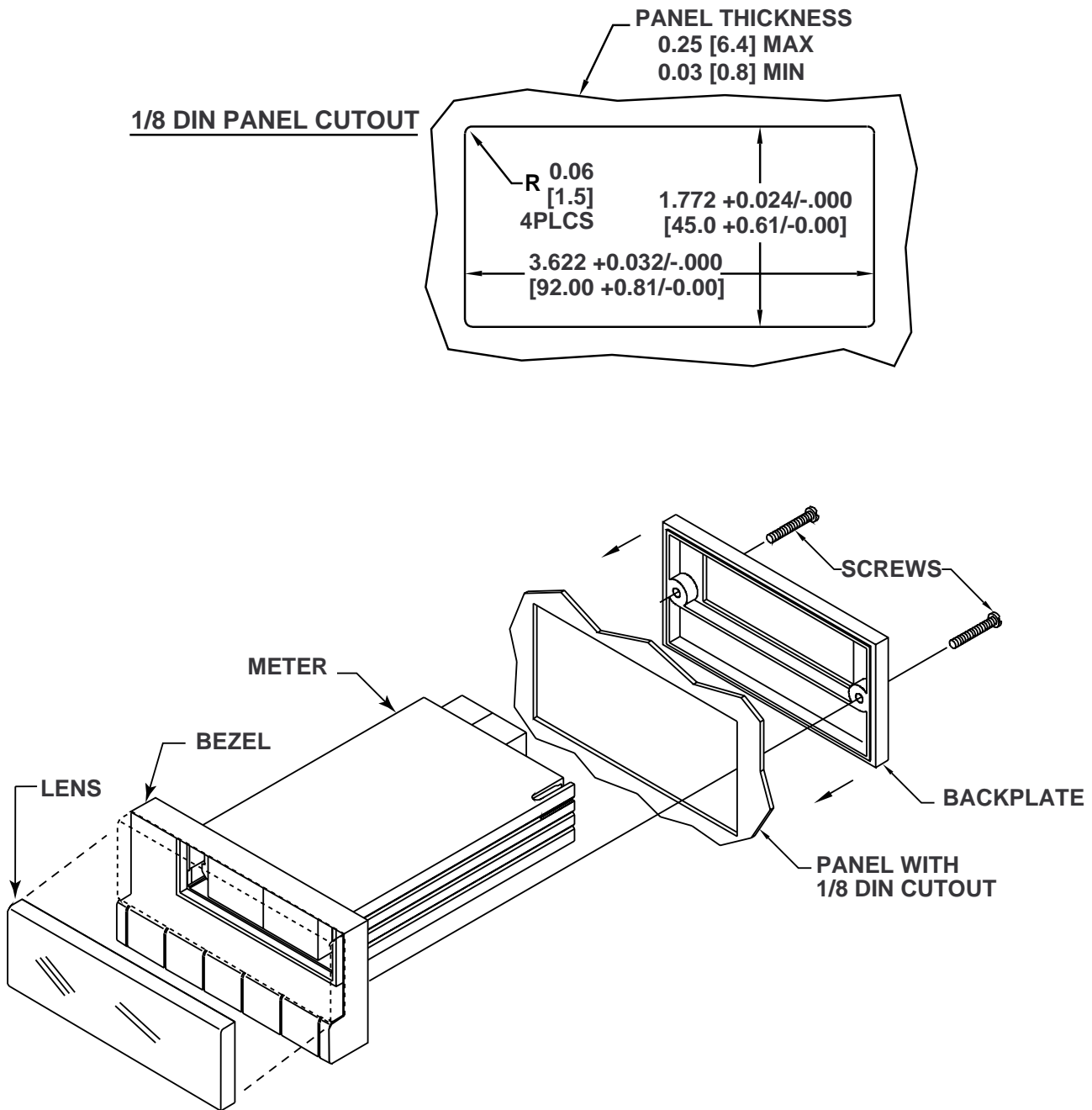

Figure 3-4. Installation Information

3.4 Sensor Input Connections

The RTD sensor (see **Figure 3-5**), can be wired in three different ways. They are 2-, 3-, and 4-wire configurations. The meter is factory set internally to a 3-wire setup. If you wish to change it, refer to **Table 3-2**.

2-Wire RTD:

Externally wire the P3 connector according to **Figure 3-6**. Keep in mind that you will need to jumper pins 1 and 2 on P3 together, and jumper pins 3 and 4 on P3 together. Use 24 AWG wire. The black lead goes to Pin 1 or 2 and the red lead goes to Pin 3 or 4.

3-Wire RTD:

Externally wire the P3 connector according to **Figure 3-7**. Pin 4 on the P3 connector is not used.

4-Wire RTD:

Externally wire the P3 connector according to **Figure 3-8**.

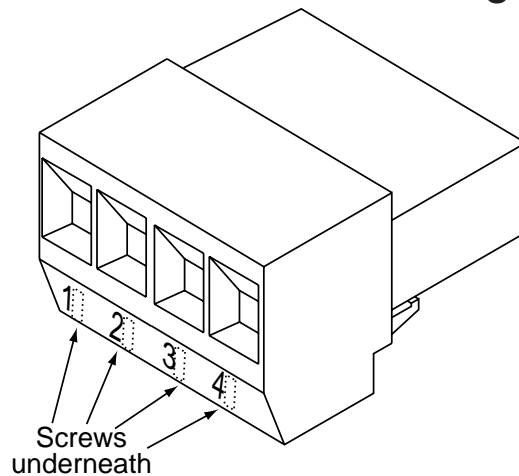

Figure 3-5. RTD P3 Connector

See **Figure 2-2** for the location of the P3 connector.

3.4 Sensor Input Connections (Continued)

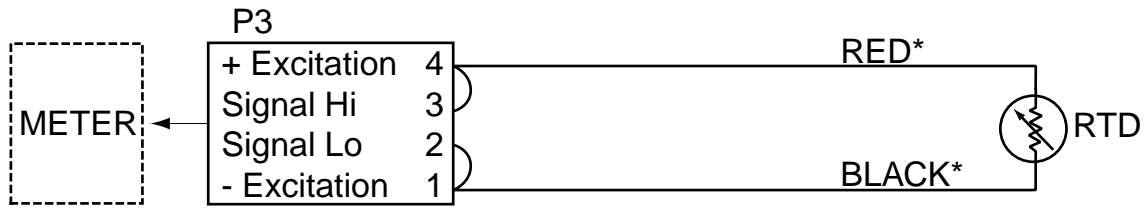

Figure 3-6. 2-Wire RTD Wiring

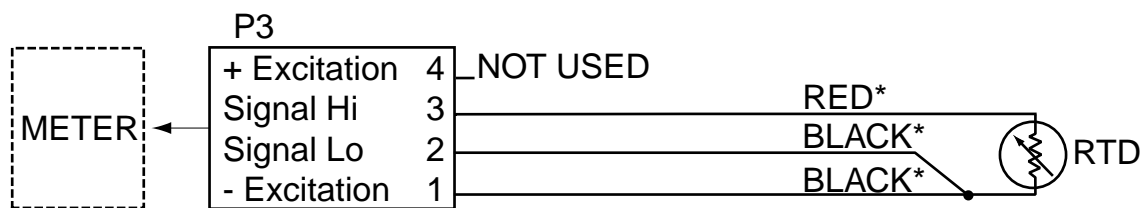

Figure 3-7. 3-Wire RTD Wiring

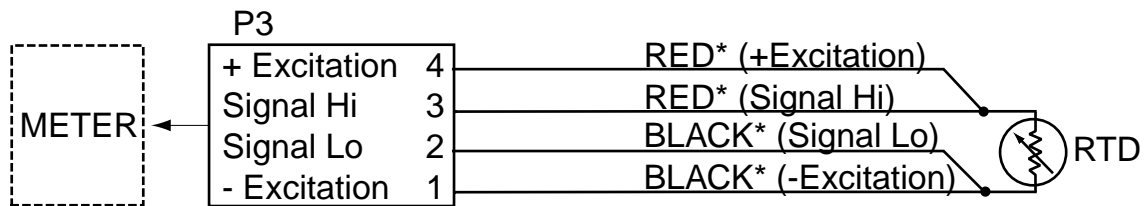

Figure 3-8. 4-Wire RTD Wiring



Refer to **Table 3-1** and **Table 3-2** for internal jumper settings.

* Wire colors are for OMEGA RTD wiring only.

3.5 Analog Output Connections

The analog output is a linearized millivolt signal that is equivalent to the displayed temperature. It comes as a standard feature with every unit. The resolution of the analog output is no greater than the resolution of the display.

Note 

The analog output is a non-isolated signal.

To access the analog signal, attach copper wire to the 3-pin female connector that is supplied with the meter. Refer to **Figure 3-9** for wiring instructions. Plug the female connector into the P2 (male) connector at the rear of the meter.

Figure 2-2 shows the location of the P2 connector on the meter. Note that this connector shares a common return with the "Display Hold" function.

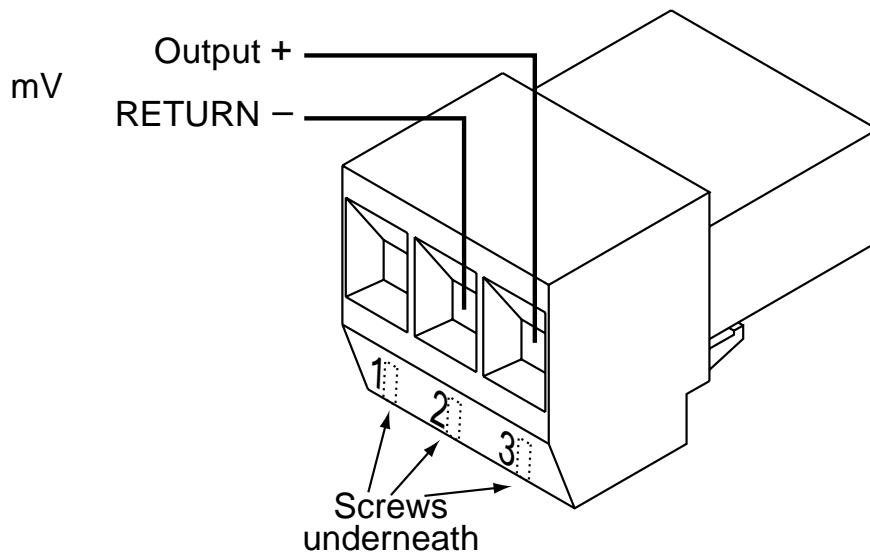

Figure 3-9. Analog Output Connections (P2)

3.6 Display Hold Connections

The "Display Hold" function can be used to freeze the display. Connect a single pole, single throw (SPST) switch between pins 1 and 2 on the P2 connector. The display will stop updating when this switch is on. When this switch is off, the display will update itself 2.5 times per second.

To access the "Display Hold" function, attach copper wire to the 3-pin female connector that is supplied with the meter. Refer to **Figure 3-10** for wiring instructions. This connector shares a common return with the Analog Output. Plug the female connector into the P2 connector at the rear of the meter.

Figure 2-2 shows the location of the P2 connector on the meter.

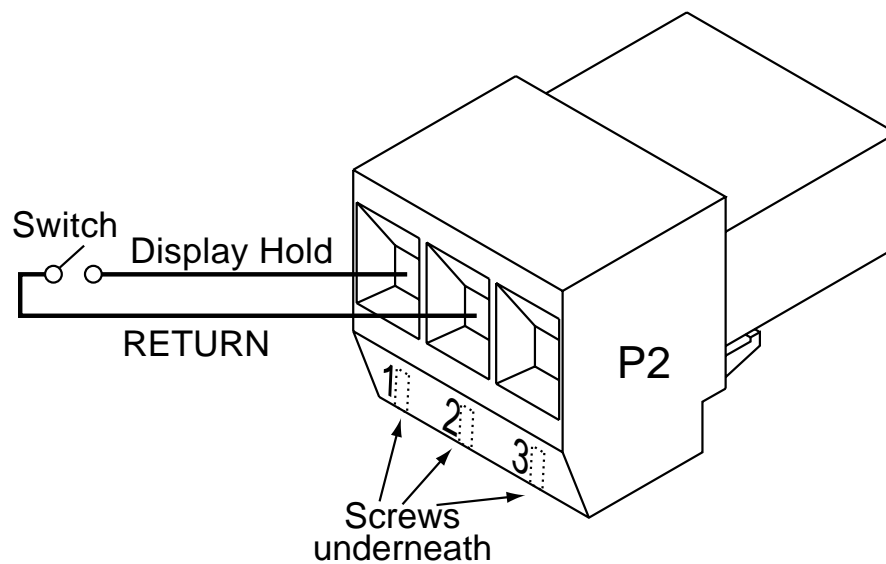

Figure 3-10. Display Hold Connections

3.7 Main Power Connections

Connect the ac main power connections as shown below.



WARNING: Do not connect ac power to your meter until you have completed all input and output connections. Failure to do so may result in injury! This device must only be installed electrically by specially trained electrician with corresponding qualifications. The main power input to the unit as well as the AC input signal to be measured must agree with the wiring instruction.

The meter is factory set to the power specified by the customer at the time of ordering. The voltage is printed on the Label under Input power.

Note 

Refer to **Section 3-2** to convert from one configuration to another

To connect power to the unit, attach wires from the \sim AC power cord to the orange 3-pin female connector that is supplied with the meter. Refer to **Figure 3-11** for wiring instructions. Plug the female connector into the orange P1 (male) connector at the rear of the meter.

Figure 2-2 shows the location of P1 on the meter.

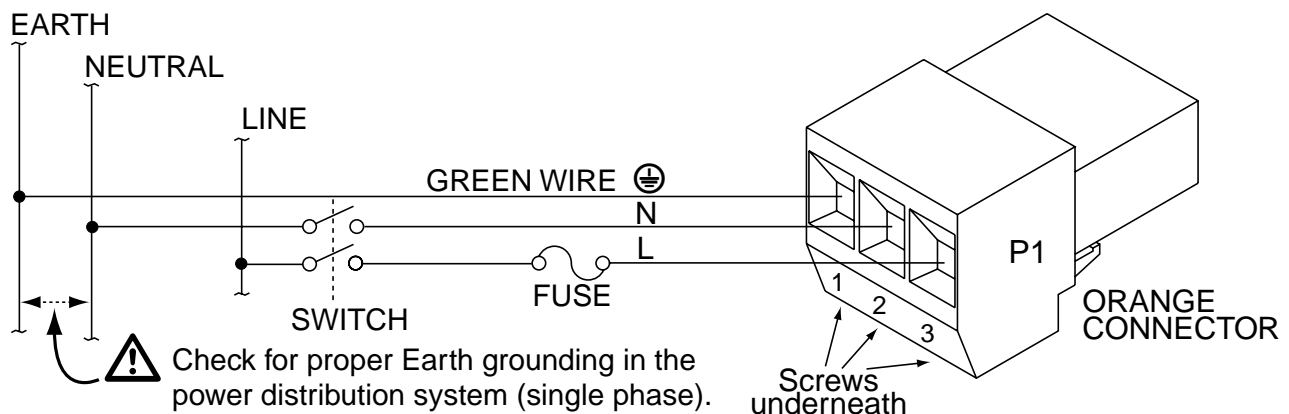

Figure 3-11. \sim AC Connector Wiring (P1)

DC WIRING

The meter can be configured at the factory to operate on a 9–26 VDC non-isolated power. The DC voltage option is specified at the time of ordering. See **Table 1-3** for model number listing. An AC powered meter cannot be converted to a DC powered meter or vice versa.

To connect power to the unit, attach the DC power wires to the orange 3-pin female connector that is supplied with the meter. Refer to **Figure 3-12** for wiring instructions. Plug the female connector into the orange P1 (male) connector at the rear of the meter.

Figure 2-2 shows the location of P1 on the meter.

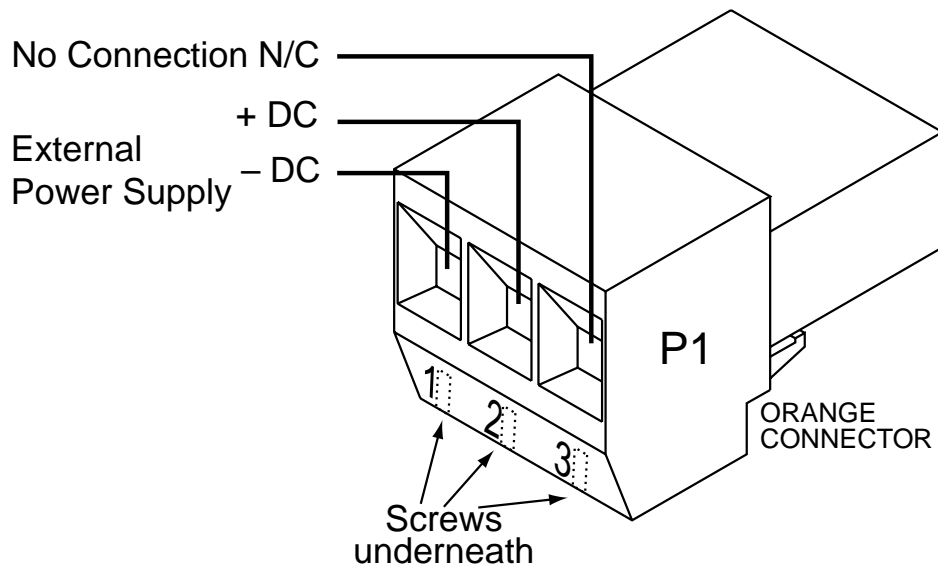

Figure 3-12. =DC Power Connector Wiring (P1)

3.8 Disassembly/Assembly



You must go through the following steps in order to remove the printed circuit board from the case if you want to change from 115VAC to 230VAC (or vice versa) or to change from Fahrenheit to Celsius (or vice versa). These changes must be performed by a qualified technician in order to avoid damage to the unit.



WARNING: Do not connect ac power to your meter until you have completed all input and output connections. Failure to do so may result in injury!

1. Remove power and all wire connections from the unit.
2. Unplug the three connectors (P1, P2, and P3) from the back of the meter. Grasp them firmly on the top and bottom of the connector and pull. **Figure 3-13** shows the location of the three connectors.
3. Remove the friction fit lens by prying down and forward from the top of the meter. Remove the mounting screws from the rear of the panel backplate. Slide the unit out of the panel (if it is installed in a panel).
4. The printed circuit board is held in place by a tab and notch system located next to the P1 connector, pin 1 (refer to **Figure 3-13**). The tab is on the case and the notch is on the edge of the PC Board. Hold the meter with the display facing away from you. Gently pry the tab (on the back corner of the case) out with the edge of your finger, while pushing the back of the PC Board out through the front of the meter. The PC Board will slide out the front, free from the case.

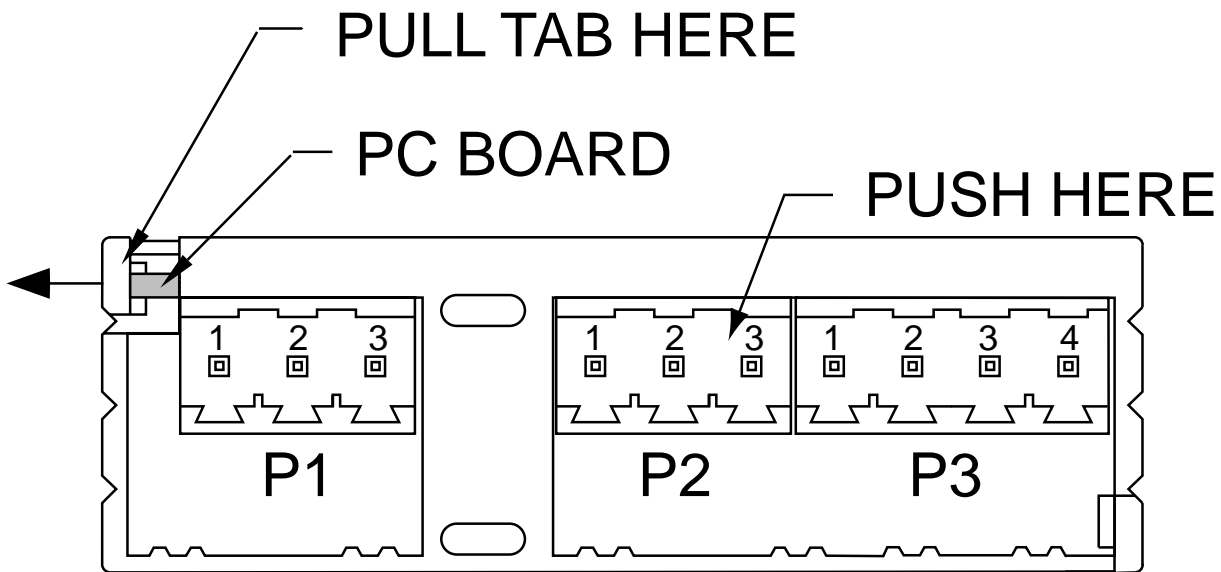

Figure 3-13. Removing the PC Board from the Case

When re-installing the printed circuit board:

1. Hold the case (with the two mounting holes facing upwards and to the right side of the case) in the left hand.
2. Hold the printed circuit board with the components showing (soldered side down) in the right hand.
3. Slip the component board into the case and slide in as far as it will go. You will also have to release the tab at the rear on the other side of the case (turn case over) to allow the board to fit all the way inside the case.
4. Go through steps 3 thru 5 in **Section 3.3** in order to re-install the backplate and screws, and also install the lens.

SECTION 4 OPERATION AND CALIBRATION



Important: These changes must be performed by a qualified technician.



WARNING: Do not connect ac power to your meter until you have completed all input and output connections. Failure to do so may result in injury!

1. Wire the meter according to the wiring section. This includes power, thermocouple and analog signal connections.
2. Apply power to the meter and the display will show the temperature of the probe.

The meter is shipped from the factory calibrated to the accuracy as specified. No re-calibration is necessary. In the event that there is a desire to check the calibration, the following procedure is given.

4.1 EQUIPMENT REQUIRED

- Meter
- a small screwdriver
- a precision resistance source in 0.01° resolution or "Decade Box".

4.2 CALIBRATION PROCEDURE

1. Remove the front lens. Connect power to the meter, observing proper wiring procedures.
2. Connect the precision resistance source to the P3 connector observing proper wiring configuration. For 3–wire connections, use pins 1, 2, 3, and 4. Refer to **Figures 4-1** through **4-3**.
3. Apply resistance input as indicated in **Table 4-1**.
4. Adjust either the **ZERO** or **SPAN** potentiometer as shown in **Figure 4-4**.
5. After adjusting the post, go back and verify both temperature readings. Repeat step 4 as required.

Note 

Refer to **Table 3-1** and **Table 3-2** for internal jumper settings.

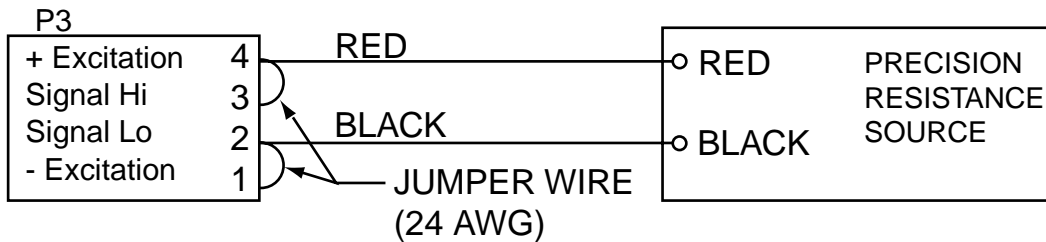

Figure 4-1. 2-Wire Configuration

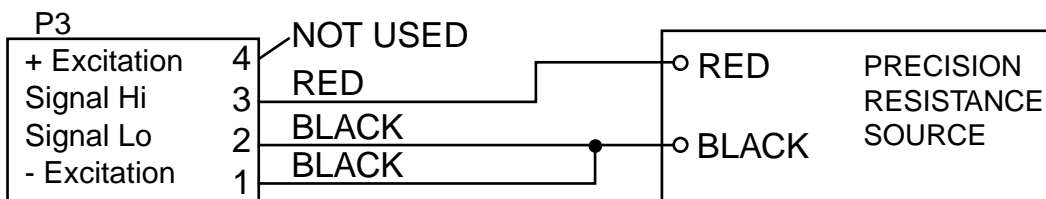

Figure 4-2. 3-Wire Configuration

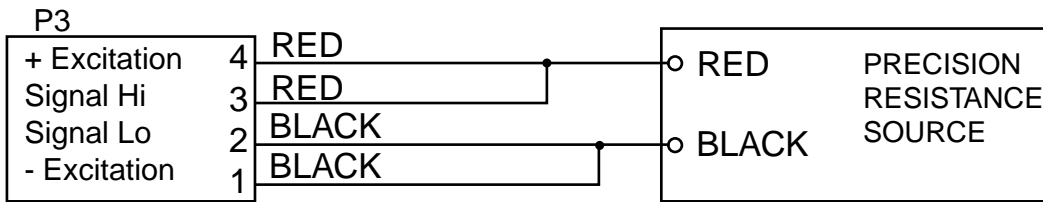

Figure 4-3. 4-Wire Configuration

TABLE 4-1

CALIBRATION VALUES WHEN YOU ARE USING RESISTANCE SOURCE

MODEL OPTION	RESISTANCE READING	METER DISPLAY	POT TO ADJUST
*-MF1	93.01 375.51	00°F 1472°F	ZERO SPAN
*-MF2	93.01 134.70	00.0°F 194.0°F	ZERO SPAN
*-MC1	100 375.51	00°C 800°C	ZERO SPAN
*-MC2	100.0°C 174.0°C	00°C 195.0°C	ZERO SPAN

* Refer to **Table 1-1**, for complete models (preface section).

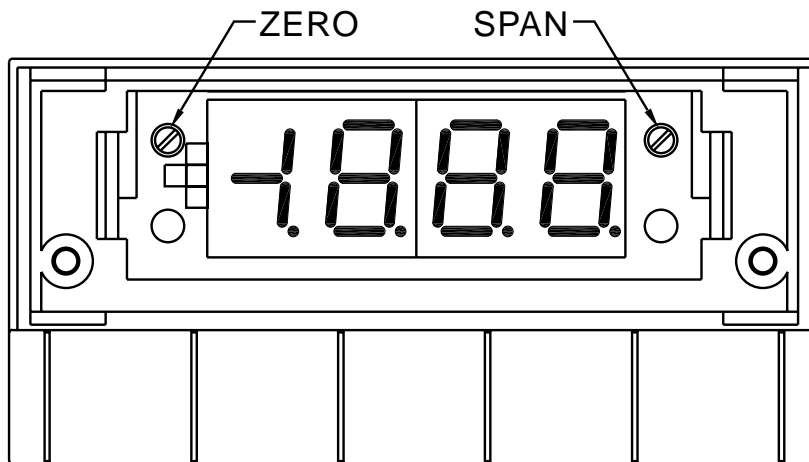

Figure 4-4. Calibration Potentiometers

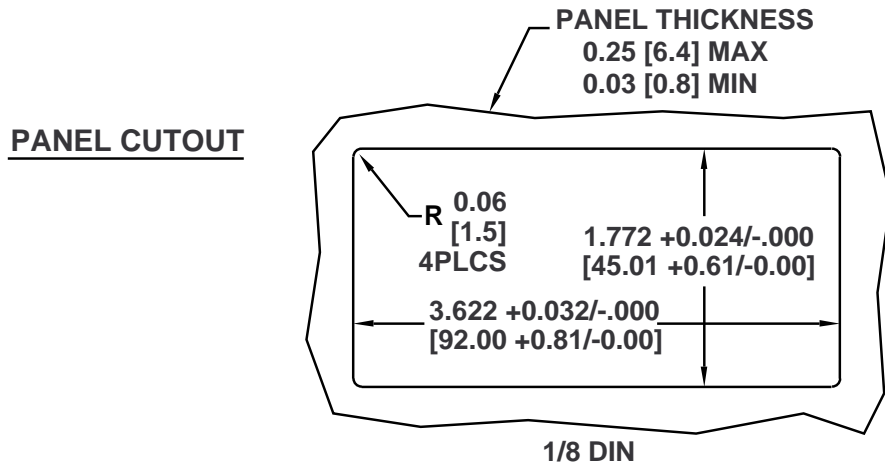
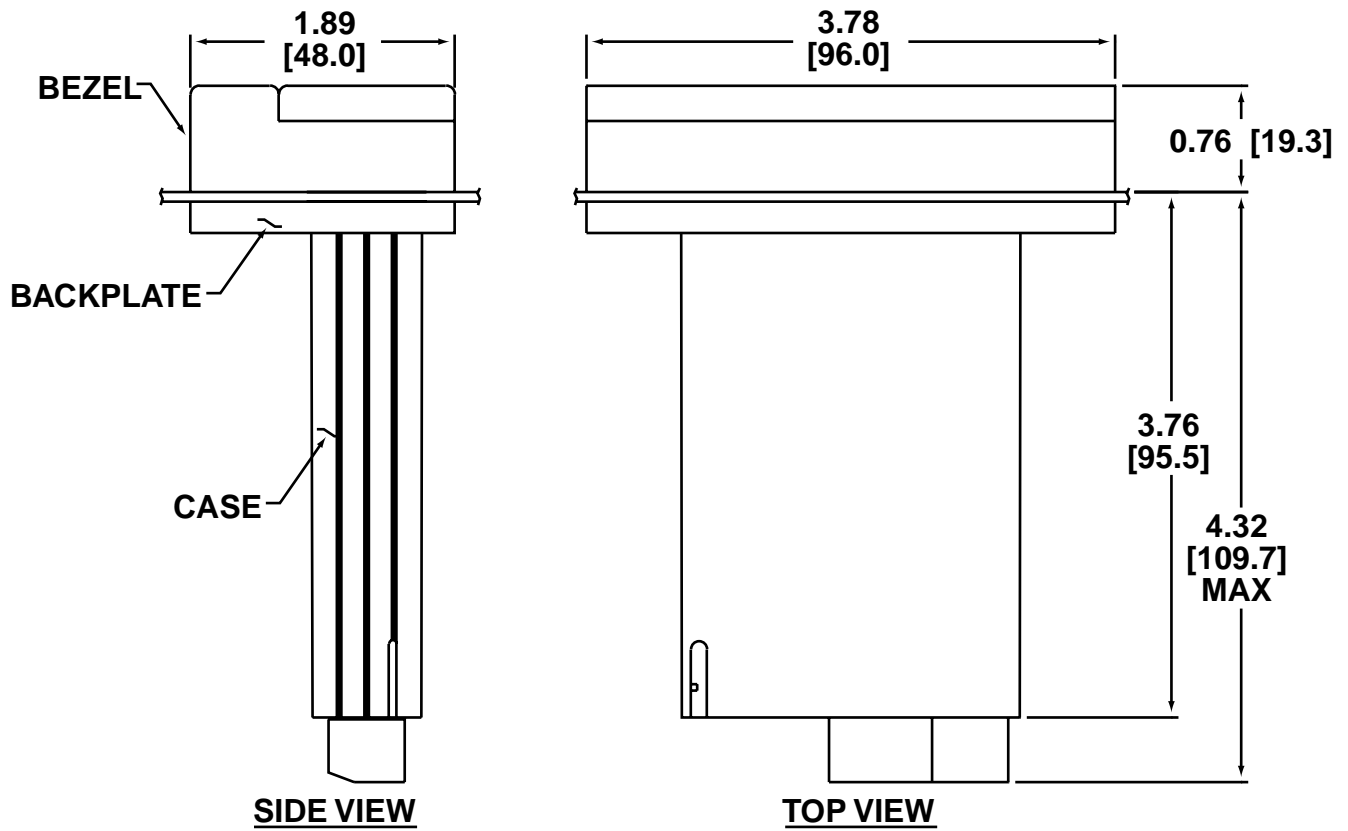

Figure 5-1 Dimensions

SECTION 6 GLOSSARY

COMMON MODE REJECTION (CMR) - a measure of the affect of a voltage on the indicated display. It is the ratio of the common mode voltage to the measured voltage due to a common mode voltage.

COMMON MODE VOLTAGE (CMV) - the average of the voltage applied to both wires of a two wire or differential input.

NORMAL MODE REJECTION (NMR) - a measure of the rejection of unwanted signal due to a voltage applied between the wires of a two wire or differential input (shown as normal mode voltage). NMR is the ratio of the normal mode voltage to the measured voltage due to the normal mode voltage.

TEMPCO - abbreviation for temperature coefficient. It is the effect of changes in ambient temperature on a particular parameter, such as zero or span settings.