

DESCRIPTION:

The iLD26 is a 6-digit master/slave display providing remote readout from instruments such as programmable controllers, digital panel meters and other instruments with serial output. Communication interfaces supported in the iLD26 are RS-232 or RS-485 standards. Both RS-232 or RS-485 are programmable through front panel buttons.

The Big Display features a large three color programmable display with the capability to change color every time an Alarm is triggered.

Note Refer to the separate Signal Conditioner Manual for your specific Input details.

SAFETY:

- The instrument is a panel mount device protected in accordance with Class III of IEC 1010.

EMC:

- Whenever EMC is an issue, always use shielded cables.
- Never run signal and power wires in the same conduit.
- Use signal wire connections with twisted-pair cables.
- Install Ferrite Bead(s) on signal wire close to the instrument if EMC problems persist.

MOUNTING

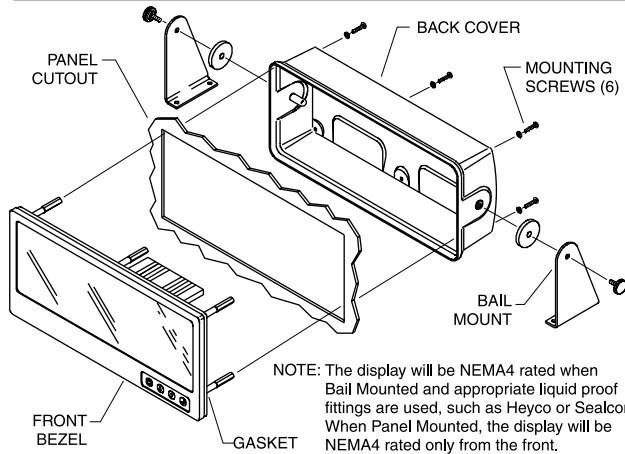
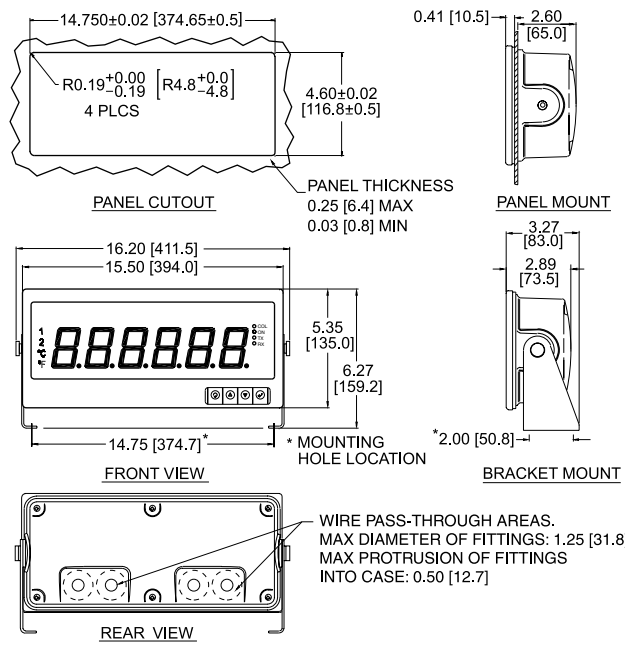

Mounting Big Display Through Panel:

- Using the panel cutout diagram shown above, cut an opening in the panel.
- Remove six screws at the back of Big Display to remove back cover.
- Insert the unit into the opening from the front of the panel, so the gasket seals between the bezel and the front of the panel.
- Align back cover to Big Display and reinstall screws.

Mounting Big Display on Bail:

- Use the Big Display template to mark the location of mounting screws on the flat surface.
- Be sure to leave enough room around the bail (as noted on the template drawing) to allow for removal and rotation of the display.
- The display can be rotated for the best viewing angle.

Disassembly Instruction:

Warning: Disconnect all ac power from the unit before proceeding.

- Remove all wiring connections from the rear of the instrument, by unscrewing the power and input connectors.
- Remove six screws at the back of the display and back cover.
- Remove the Big Display from the panel.
- To remove the Big Display from the bail, unscrew the two knobs at each end of the mounting brackets.

WIRING

1. Wiring RS-232 Interface.

The RS-232 standard (point-to-point) allows a single device to be connected to the Big Display using a three-wire connection (full duplex).

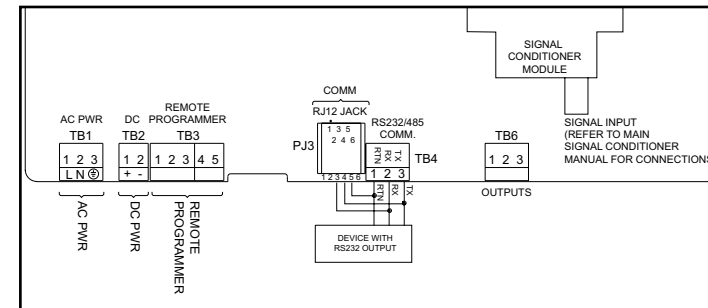

Device with RS-232 Pin Function	Large Remote Display	
	RJ-12	Screw Terminal
Receive (Rx)	4 (Tx)	3 (Tx)
Transmit (Tx)	3 (Rx)	2 (Rx)
Common Ground (COM)	5	1

2. Wiring RS-485 Interface.

The RS-485 standard (multipoint) allows a computer, one or more devices and Big Displays (up to 32) to be connected using a two-wire connection (half-duplex) plus a common wire to connect to the shield of the cable. It is recommended to use shielded cable with one twisted pair for EMI noise protection.

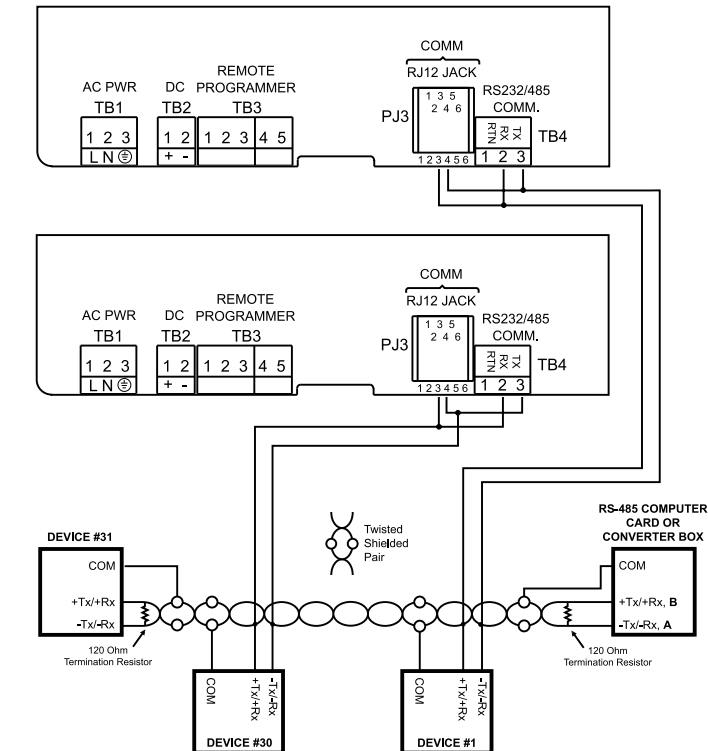

Note Connections to the computer are optional.

Computer Card or Converter Box Pin Function	Device with RS-485 Pin Function	Remote Display	
		RJ-12	Screw Terminal
A, -Tx/-Rx	-Tx/-Rx	4	3
B, +Tx/+Rx	+Tx/+Rx	3	2
COM	COM		1

3. Power Connection.

Connect the main power connections as shown in the figure below.

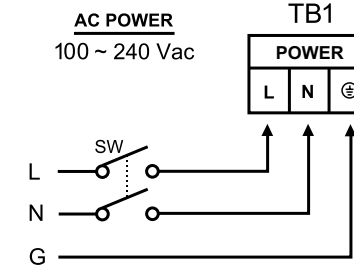

OPERATIONS

1. Peak Value (Display in Host Mode)

Press **▲** to request "Peak" value:

- RS-232 Mode, will send: *X02 (Interface DRNT), or *X03 (Interface DRNP)
- RS-485 Mode, will send: *01X02 (Interface DRNT), or *01X03 (Interface DRNP)

Note In the examples for RS-485 it is assumed that the device address is 01.

2. Valley Value (Display on Host Mode)

Press **▼** to request "Valley" value.

- RS-232 Mode, will send: *X03 (Interface DRNT), or *X04 (Interface DRNP)
- RS-485 Mode, will send: *01X03 (Interface DRNT), or *01X04 (Interface DRNP)

3. Process Value (Display on Host Mode)

Press **▶** to request "Process" Value.

- RS-232 Mode, will send: *X01
- RS-485 Mode, will send: *01X01

4. Write alphanumeric characters to the Big Display from the computer (Display in Slave Mode)

- Single Big Display: (RS232) write 4(6) characters, then CR (carriage return)
- Multiple Big Display: (RS485) write *, device address (2 digit), CR, 4(6) characters, then CR

5. Display Color Setup (Alarm Setup)

This menu allows the user to select the color of the display in normal conditions and when alarm is triggered. If user wants the Display to change color every time when both Alarm 1 and Alarm 2 are triggered, the Alarm values should be set in such a way that Alarm 1 is always on the top of Alarm 2 value, otherwise value of the Alarm 1 will overwrite value of Alarm 2 and Display color would not change when Alarm 2 is triggered.

Example 1:

Alarm 1 setup: "ON", Alarm Mode High "A1HI", Alarm High Value "HI-1"=400, Alarm Color "A1CR"=Amber
Alarm 2 setup: "ON", Alarm Mode High "A2HI", Alarm High Value "HI-2"=200, Alarm Color "A2CR"=Red
Normal Color: "NO.CR"=Green

Display colors change sequences:

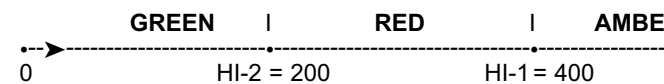

Example 2:

Alarm 1 setup: "ON", Alarm Mode Low "A1LO", Alarm Low Value "LO-1"=100, Alarm Color "A1CR"=Amber
Alarm 2 setup: "ON", Alarm Mode LO "A2LO", Alarm High Value "LO-2"=300, Alarm Color "A2CR"=Red
Normal Color: "NO.CR"=Green

Display colors change sequences:

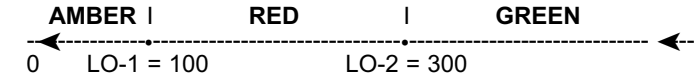

Example 3:

Alarm 1 setup: "ON", Alarm Mode Low/High "A1LH", Alarm Low Value "LO-1"=100, Alarm High Value "HI-1"=250, Alarm Color "A1CR"=Amber
Alarm 2 setup: "ON", Alarm Mode Low/High "A2LH", Alarm Low Value "LO-2"=150, Alarm High value "HI-2"=200, Alarm Color "A2CR"=Red
Normal Color: "NO.CR"=Green

Display colors change sequences:

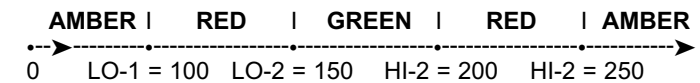

CONFIGURATION

Button Functions in Configuration Mode

⊙ (MENU)	<ul style="list-style-type: none"> To enter the Menu, the user must first press ▶ button. Use this button to advance/navigate to the next menu item. The user can navigate through all the top level menus by pressing ▶. While a parameter is being modified, press ▶ to escape without saving the parameter.
▲ (UP)	<ul style="list-style-type: none"> Press the up ▲ button to scroll through submenu selections. When a numerical value is displayed press this key to increase value of a parameter that is currently being modified. In the Run Mode pressing ▲ causes the display to flash the PEAK value several times before returning to the Run Mode. In the top menu press ▲ causes the display to return to the Run Mode.
▼ (DOWN)	<ul style="list-style-type: none"> Press the down ▼ button to scroll through submenu selections. When a numerical value is displayed press this key to decrease value of a parameter that is currently being modified. In the Run Mode press ▼ causes the display to flash the Valley value several times before returning to the Run Mode. In the top menu press ▼ causes the display to return to the Run Mode.
⊙ (ENTER)	<ul style="list-style-type: none"> Press this button to access the submenus from a Top Level Menu item. Press this button to store a submenu selection or after entering a value – the display will flash a S E T message to confirm your selection.

Note x, w, z, and some punctuations are non-printable characters.